

この街の いいね を届けます

# エリート情報 *Take Free*



## ほしい情報をタイムリーに届ける 地域密着型の生活情報紙です!

千葉県成田地区および茨城県南地区に、新聞折込みで無料配布しているフリーペーパーです。昭和48(1973)年の創刊から約40年が経った現在でも、読者やクライアントから「地元に着した情報紙」として厚い信頼を得ております。

### エリート情報を読む頻度

成田版読者アンケート結果より(2017年) 回答435名

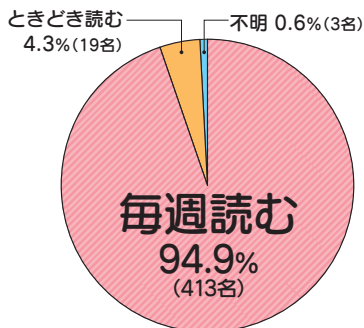

毎週土曜日発行

創刊40年の地域認知力

確実な新聞折込・設置

タイムリーな情報

8割以上が女性読者

総発行部数

**14万5千部**

(2021年9月現在)

読売・朝日・毎日の3大新聞(一部産経含む)に折込形式で配布しています! その他、大型ショッピングモール等設置店舗多数

エリア	発行日	発行部数	発行エリア
成田版	毎週 土曜	65,000部	千葉県成田市、富里市、栄町、酒々井町、多古町、芝山町、印西市の一部(旧印旛村、旧本埜村)
茨城県南版	第1・3週土曜	80,000部	茨城県牛久市、龍ヶ崎市、つくば市(旧荃崎町)、土浦市荒川沖、阿見町、稲敷市・河内町の一部

### 茨城県南版

発行日…第1・3週土曜日  
発行部数…80,000部

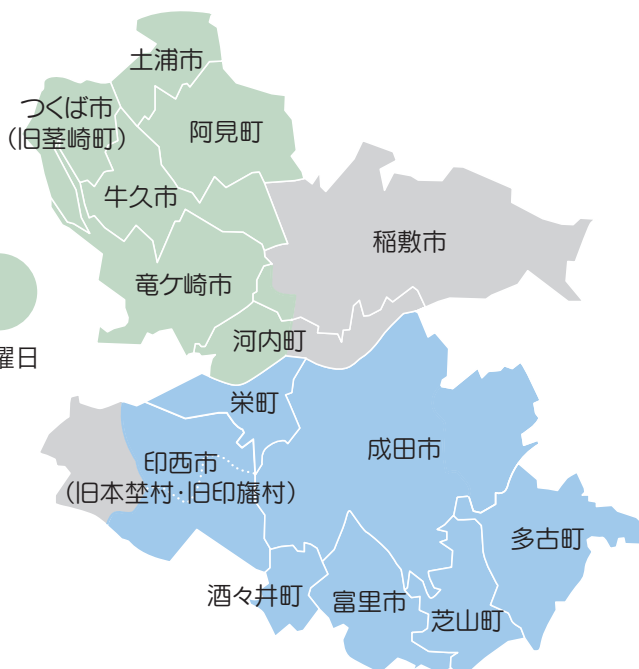

### 成田版

発行日…毎週土曜日  
発行部数…65,000部

成田版紙面において、読者アンケートを行ったところ  
有職者や主婦を中心に多くの女性に読まれています。  
またその配偶者、家族にも支持されています。  
年齢層は40代～60代が中心で、時間や経済的にも余裕のある層です。

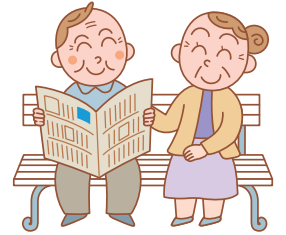

男女別

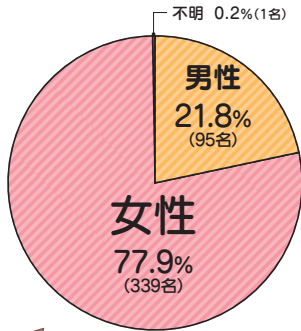

職業

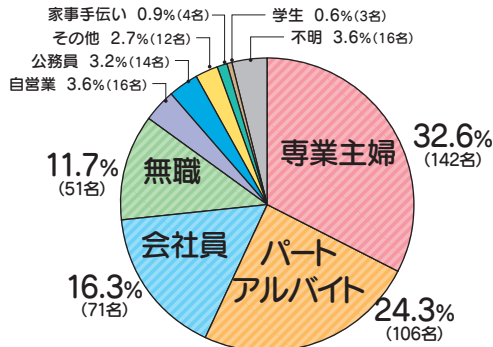

年齢

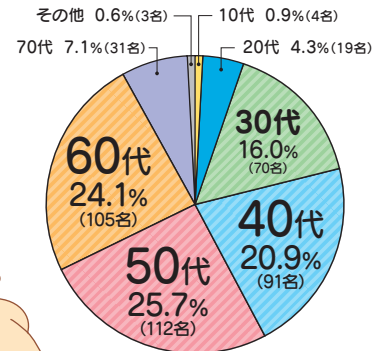

市町村

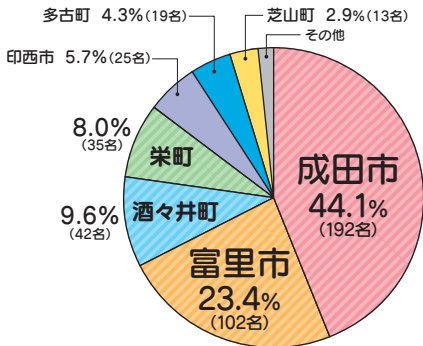

読者歴

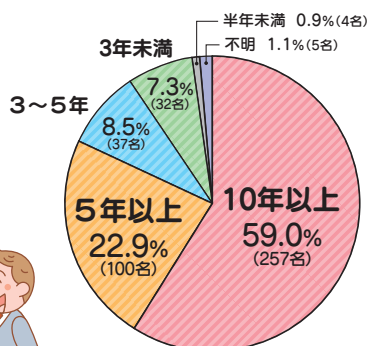

同居家族について

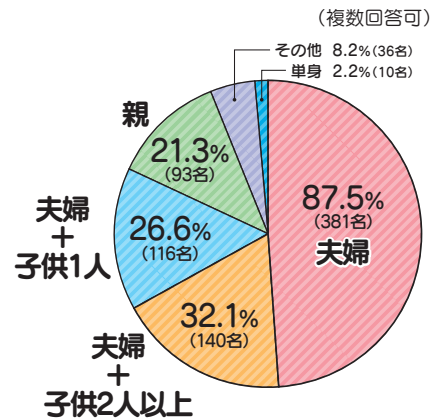

既読後の紙面

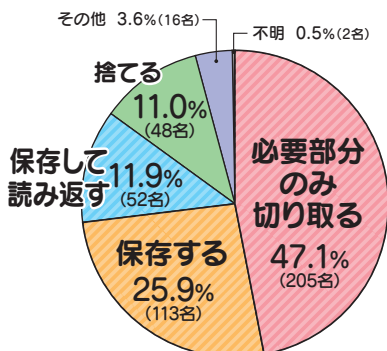

保存の理由

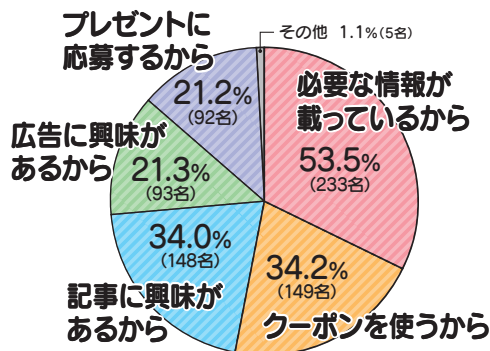

紙面内で関心ある情報

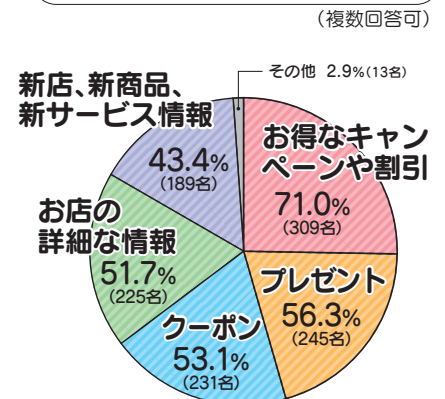

スタッフがホットな話題や皆さまに役立つ情報をお届けしています。

1面・中面記事

10/10 1660\*

北総うまいもん栄町 丹波黒大豆

どらまめ

10/24 1662\*

Happy Hallmakers

一軒家で 期間限定 ハロウィンの 不思議な世界

0476-22-3904

0476-33-0113

「杜の音楽会」vol.1

24日、成田市公津の杜で

中村由利子さんとアキダスのコラボ

アキダスとアキダス

中村由利子さん

中学生剣士たちが熱戦

成田ロータリークラブ中学校剣道大会

上=男子団体優勝の成田市立成田中学校

下=女子団体優勝の重実市立重実中学校

記事広告

記事タイプの広告です。文章でより詳細な内容を伝えることができます。

どうぶつ相殺

動物の骨折

動物の骨折

動物の骨折

枠広告

枠タイプの広告です。規定内で自由なイメージの広告ができます。

12/19 リニューアル OPEN

プロショップ オープニングセール開催!

PLAY FEE

12/14~25 7,500円

12/28-29 11,500円

12/30-31 13,500円

0476-73-7712

千し芋 工場直売

直売所 リニューアル オープン

人気のオススメ商品

- 定番はるかさん (100g) 450円 (180g) 800円
- はるかさん わけありパック 1,000円
- はねだしはるかさんお後用 450円
- ちっちゃい焼き芋 300円

結婚

女性 全て無償

コロナ対策万全

あー勇気を出して行ってよかった

090-8315-8998

090-4173-4814

卒業袴フェア

11/21~24

最新ブランド袴大発表

0476-33-0113

お客様感謝セール開催

11/21~29日 9:00~16:00

ハンダービオ祭り

50円!! 5,000円

0476-37-5517

動物の骨折

動物の骨折

動物の骨折

「Google」式10Xリモート仕事術

10Xリモート仕事術

0476-23-1111

http://www.hiwayana.com/





その他

「気になる噂の現場!」 気になってること・ものをスタッフが調査します!

「気になる噂の現場!」 エリート調査隊がゆく!

ショッピングセンターの賑わいの中に立つ全身緑のスラリとした長身。これは何? とのぞいてみると「Pocketchange」の表示。海外旅行で使い残したお金を電子マネーやギフト券などと交換できる。そう言えば、夏にフランスに行った時投入した金額がチャージされたってわけ。ホン

ユーロが結構残っていた。たっけ。翌日それを持ってさっそくお試し。お金を入れると何に交換したかが表示されるので「金額を選んでみましょ」を案内に従ってカードを当てるとそれがもうOK。投入した金額分がチャージされたってわけ。ホン

余った外国のお金を電子マネーやギフト券に。簡単・便利・安心な「ポケットチェンジ」

入力不要、タッチパネルだけの簡単操作で、あっという間に完了!

スマートフォンで、個人情報を入力したりする必要もないので安心。外貨だけでなく日本円も使えます。

「誕生月占い」 月初めに掲載

1か月をハッピーに過ごす Lucy・Word つき! 誕生月占い 1.1 ~ 1.31 認定占術士 渡なべ 尚子 TEL 090-3542-1816

<p>1月 January ★★★★★</p> <p>人と交流を深め話題を豊富にしよう。動触に心がけて。口先だけは駄目。 ①① 楽しみ・喜び</p>	<p>5月 May ★★★★★</p> <p>広い心で対処しよう。知らないうちに差別言動をとらないよう注意を。 ①① 丁寧・仲間</p>	<p>9月 September ★★★★★</p> <p>自分を見つめ直すことを常に忘れない。悪病や不満は災いの元。 ①① 初心・基本</p>
<p>2月 February ★★★★★</p> <p>周りの人から知恵をもらい視野を広げよう。独断・独りよがりには避ける。 ①① 協力・改善</p>	<p>6月 June ★★★★★</p> <p>高望みや多大な期待はやめよう。油断大敵。欲張ると悪い結果に。 ①① 礼儀・余裕</p>	<p>10月 October ★★★★★</p> <p>身近な人への感謝をいつも忘れないように。邪念は捨てよう。 ①① ガマン・目標</p>
<p>3月 March ★★★★★</p> <p>譲り合いの精神を忘れず。短気は損気。急ブレーキにも注意を。 ①① 順調・着実</p>	<p>7月 July ★★★★★</p> <p>焦らず物事を静観し見守る気持ちで。機柄な態度、誤解される行動に注意。 ①① 整理・整頓</p>	<p>11月 November ★★★★★</p> <p>やるべきことをやりながらチャンス待とう。余計なプライドは捨てて。 ①① 貯蓄・堅実</p>
<p>4月 April ★★★★★</p> <p>いつも落ち着いた行動ができるよう心掛け。道徳を守る意識を持って。 ①① 知恵・賢者</p>	<p>8月 August ★★★★★</p> <p>穏やかに慎重に対処を。性急な行動は逆効果。無神経な言動に注意。 ①① 知恵・用心</p>	<p>12月 December ★★★★★</p> <p>良い協力者が得られる期待大。物事はよく考えて。礼儀作法に注意。 ①① やる気・挑戦</p>

「君の名は」 読者投稿によるわが子の命名の話

はじめての贈り物... 命名の由来をご紹介

君の名は 真希ちゃん

待望の子どもができた時に「あなたは本当にのぞまれて生まれた子」という気持ちと、「将来希望に真つすぐ向かって生きてほしい」と思いを込めて名付けました。

お子様の名前の由来・エピソード、3歳頃までのお子様の写真データ、氏名(ペンネームも可)、ご連絡先等を弊社HPまたは右のコードより送ってください。

ご投稿中

〈成田市 ジャスミンティーさん〉

「飛び出せ! ゲンキッズ」 サークル等を通して頑張る少年少女をご紹介!

飛び出せ! GEN Kids!!

げんきっず!!

牛久市 牛久ソウルアタッカーズ

井野 茂 監督  
色々な学年の仲間や他のチームとの交流を通して助け合う心を学んでもらいたいです。

勝負は5分。楽しくまじめに競技ドッジボール!

子ども会のドッジボールが盛んだった牛久市で2011年に誕生。小学3年生~6年生の男女19人が汗を流している。競技時間の5分間でいかに内野を残すかが鍵になるという競技ドッジボール。技術以上に基礎体力を強化することが、ここぞという時の踏ん張りにつながるという。そのために準備運動や地道なトレーニングもしっかりこなす。楽しいときもつらいときもあるけれど、ドッジボールを通して「やり切ること」を学んでほしいと井野監督。小学生時代にしっかりやり切って欲しいと願う。練習の前には体育館に向かって「お願いします!」と元気にあいさつ。大きな掛け声で真面目に楽しく元気よく! きょうも仲間と一緒に声を出して! 練習日▶毎週月・木・金曜19:00~21:00(牛久三中)、第2・3土曜13:00~17:00(牛久小)

「読者プレゼント」

読者プレゼント 2月6日必着

福田こうへいコンサートツアー2020 夜の部公演チケットを5組10名様に

福田こうへいさんのファンの方はもちろん、演歌好きの方なら注目です。演歌界の新星が民謡仕込みの魅惑の歌声で客席を魅了する、圧巻のステージをお楽しみください!

●期日/2月19日(水)  
●昼の部/13時30分開演 ●夜の部/18時開演  
●会場/成田国際文化会館大ホール  
●入場料/S席 6,800円(税込)  
●チケット販売/H Pをご確認ください。  
http://www.bellworldmusic.com

応募方法

〒住所・氏名・年齢・電話番号を明記の上、ハガキでご応募ください。発表は発送をもって代えさせていただきます。応募者は主催者より公演案内をお送りさせていただきます。  
〒102-0082 東京都千代田区一番町6-1 ロイヤル一番町A-201 株式会社ワールドミュージック「福田こうへいエリート読者」係

●代理店様のマージンは下記掲載料金の20%分となります。連続掲載による回数割引の適用はございません。  
(表示価格がグロス価格。ネット価格は×0.8となります)

## 広告掲載料金 (単位:円)

版	成田版	茨城県南版	広告サイズ (単位 mm)
★ 1/2	32,000	30,000	61×59(縦型) 29×120(横型)
★ 1	53,000	50,000	61×120(縦型) 29×244(横型)
1 1/2	79,000	75,000	92×120
2	106,000	100,000	124×120(縦型) 61×244(横型)
3	159,000	150,000	92×244
4	212,000	200,000	124×244
5	265,000	250,000	156×244
6	318,000	300,000	186×244
7	371,000	350,000	215×244
8	424,000	400,000	246×244
9	477,000	450,000	277×244
10	530,000	500,000	308×244
11	583,000	550,000	339×244
12	636,000	600,000	375×244
表題字脇	19,000	18,000	34×59
裏題字脇	15,000	14,000	28×59
突き出し	40,000	40,000	61×59
ハサミ小	8,000	—	27×18
ハサミ大	16,000	15,000	成田版27×36 県南版24×35
スクランブル	1行につき1,000		

(消費税は別途となります)

### ★ 2段1/4(1/2段) 枠

成田版定価

グロス **32,000円**(税別)  
(タテ61mm×ヨコ59mm)

ネット **25,600円**(税別)

茨城県南版定価

グロス **30,000円**(税別)  
(タテ61mm×ヨコ59mm)

ネット **24,000円**(税別)

### ★ 半2段(1段) 枠

成田版定価

グロス **53,000円**(税別) ネット **42,400円**(税別)  
(タテ61mm×ヨコ120mm)

茨城県南版定価

グロス **50,000円**(税別) ネット **40,000円**(税別)  
(タテ61mm×ヨコ120mm)

その他、詳しくは営業担当にお問い合わせください

広告掲載のスケジュールは以下のような流れになっております。  
毎週土曜日が発行日になります。

日	月	火	水	木	金	土
1	2	3	4	5	6	7
8	9	10	11	12	13	14
15	16	17	18	19	20	21
22	23	24	25	26	27	28
29	30	31				

● 原稿締切日 ● 校了日 ● 発行日

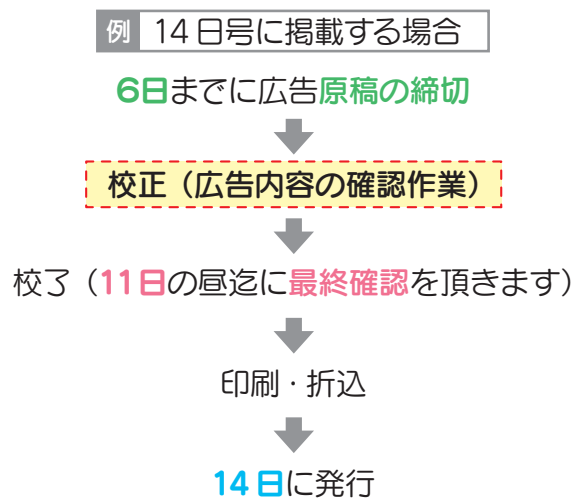

## 年間発行予定

2022年1月～12月

「成田版」発行予定 (変更になる場合がございます)

● 印が発行予定日

<p>1 January</p> <table border="1"> <tr><td>SUN</td><td>MON</td><td>TUE</td><td>WED</td><td>THU</td><td>FRI</td><td>±</td></tr> <tr><td>26</td><td>27</td><td>28</td><td>29</td><td>30</td><td>31</td><td>1</td></tr> <tr><td>2</td><td>3</td><td>4</td><td>5</td><td>6</td><td>7</td><td>8</td></tr> <tr><td>9</td><td>10</td><td>11</td><td>12</td><td>13</td><td>14</td><td>15</td></tr> <tr><td>16</td><td>17</td><td>18</td><td>19</td><td>20</td><td>21</td><td>22</td></tr> <tr><td>23</td><td>24</td><td>25</td><td>26</td><td>27</td><td>28</td><td>29</td></tr> <tr><td>30</td><td>31</td><td>1</td><td>2</td><td>3</td><td>4</td><td>5</td></tr> </table>	SUN	MON	TUE	WED	THU	FRI	±	26	27	28	29	30	31	1	2	3	4	5	6	7	8	9	10	11	12	13	14	15	16	17	18	19	20	21	22	23	24	25	26	27	28	29	30	31	1	2	3	4	5	<p>2 February</p> <table border="1"> <tr><td>SUN</td><td>MON</td><td>TUE</td><td>WED</td><td>THU</td><td>FRI</td><td>±</td></tr> <tr><td>30</td><td>31</td><td>1</td><td>2</td><td>3</td><td>4</td><td>5</td></tr> <tr><td>6</td><td>7</td><td>8</td><td>9</td><td>10</td><td>11</td><td>12</td></tr> <tr><td>13</td><td>14</td><td>15</td><td>16</td><td>17</td><td>18</td><td>19</td></tr> <tr><td>20</td><td>21</td><td>22</td><td>23</td><td>24</td><td>25</td><td>26</td></tr> <tr><td>27</td><td>28</td><td>1</td><td>2</td><td>3</td><td>4</td><td>5</td></tr> </table>	SUN	MON	TUE	WED	THU	FRI	±	30	31	1	2	3	4	5	6	7	8	9	10	11	12	13	14	15	16	17	18	19	20	21	22	23	24	25	26	27	28	1	2	3	4	5	<p>3 March</p> <table border="1"> <tr><td>SUN</td><td>MON</td><td>TUE</td><td>WED</td><td>THU</td><td>FRI</td><td>±</td></tr> <tr><td>27</td><td>28</td><td>1</td><td>2</td><td>3</td><td>4</td><td>5</td></tr> <tr><td>6</td><td>7</td><td>8</td><td>9</td><td>10</td><td>11</td><td>12</td></tr> <tr><td>13</td><td>14</td><td>15</td><td>16</td><td>17</td><td>18</td><td>19</td></tr> <tr><td>20</td><td>21</td><td>22</td><td>23</td><td>24</td><td>25</td><td>26</td></tr> <tr><td>27</td><td>28</td><td>29</td><td>30</td><td>31</td><td>1</td><td>2</td></tr> </table>	SUN	MON	TUE	WED	THU	FRI	±	27	28	1	2	3	4	5	6	7	8	9	10	11	12	13	14	15	16	17	18	19	20	21	22	23	24	25	26	27	28	29	30	31	1	2	<p>4 April</p> <table border="1"> <tr><td>SUN</td><td>MON</td><td>TUE</td><td>WED</td><td>THU</td><td>FRI</td><td>±</td></tr> <tr><td>27</td><td>28</td><td>29</td><td>30</td><td>31</td><td>1</td><td>2</td></tr> <tr><td>3</td><td>4</td><td>5</td><td>6</td><td>7</td><td>8</td><td>9</td></tr> <tr><td>10</td><td>11</td><td>12</td><td>13</td><td>14</td><td>15</td><td>16</td></tr> <tr><td>17</td><td>18</td><td>19</td><td>20</td><td>21</td><td>22</td><td>23</td></tr> <tr><td>24</td><td>25</td><td>26</td><td>27</td><td>28</td><td>29</td><td>30</td></tr> </table>	SUN	MON	TUE	WED	THU	FRI	±	27	28	29	30	31	1	2	3	4	5	6	7	8	9	10	11	12	13	14	15	16	17	18	19	20	21	22	23	24	25	26	27	28	29	30
SUN	MON	TUE	WED	THU	FRI	±																																																																																																																																																																												
26	27	28	29	30	31	1																																																																																																																																																																												
2	3	4	5	6	7	8																																																																																																																																																																												
9	10	11	12	13	14	15																																																																																																																																																																												
16	17	18	19	20	21	22																																																																																																																																																																												
23	24	25	26	27	28	29																																																																																																																																																																												
30	31	1	2	3	4	5																																																																																																																																																																												
SUN	MON	TUE	WED	THU	FRI	±																																																																																																																																																																												
30	31	1	2	3	4	5																																																																																																																																																																												
6	7	8	9	10	11	12																																																																																																																																																																												
13	14	15	16	17	18	19																																																																																																																																																																												
20	21	22	23	24	25	26																																																																																																																																																																												
27	28	1	2	3	4	5																																																																																																																																																																												
SUN	MON	TUE	WED	THU	FRI	±																																																																																																																																																																												
27	28	1	2	3	4	5																																																																																																																																																																												
6	7	8	9	10	11	12																																																																																																																																																																												
13	14	15	16	17	18	19																																																																																																																																																																												
20	21	22	23	24	25	26																																																																																																																																																																												
27	28	29	30	31	1	2																																																																																																																																																																												
SUN	MON	TUE	WED	THU	FRI	±																																																																																																																																																																												
27	28	29	30	31	1	2																																																																																																																																																																												
3	4	5	6	7	8	9																																																																																																																																																																												
10	11	12	13	14	15	16																																																																																																																																																																												
17	18	19	20	21	22	23																																																																																																																																																																												
24	25	26	27	28	29	30																																																																																																																																																																												
<p>5 May</p> <table border="1"> <tr><td>SUN</td><td>MON</td><td>TUE</td><td>WED</td><td>THU</td><td>FRI</td><td>±</td></tr> <tr><td>1</td><td>2</td><td>3</td><td>4</td><td>5</td><td>6</td><td>7</td></tr> <tr><td>8</td><td>9</td><td>10</td><td>11</td><td>12</td><td>13</td><td>14</td></tr> <tr><td>15</td><td>16</td><td>17</td><td>18</td><td>19</td><td>20</td><td>21</td></tr> <tr><td>22</td><td>23</td><td>24</td><td>25</td><td>26</td><td>27</td><td>28</td></tr> <tr><td>29</td><td>30</td><td>31</td><td>1</td><td>2</td><td>3</td><td>4</td></tr> </table>	SUN	MON	TUE	WED	THU	FRI	±	1	2	3	4	5	6	7	8	9	10	11	12	13	14	15	16	17	18	19	20	21	22	23	24	25	26	27	28	29	30	31	1	2	3	4	<p>6 June</p> <table border="1"> <tr><td>SUN</td><td>MON</td><td>TUE</td><td>WED</td><td>THU</td><td>FRI</td><td>±</td></tr> <tr><td>29</td><td>30</td><td>31</td><td>1</td><td>2</td><td>3</td><td>4</td></tr> <tr><td>5</td><td>6</td><td>7</td><td>8</td><td>9</td><td>10</td><td>11</td></tr> <tr><td>12</td><td>13</td><td>14</td><td>15</td><td>16</td><td>17</td><td>18</td></tr> <tr><td>19</td><td>20</td><td>21</td><td>22</td><td>23</td><td>24</td><td>25</td></tr> <tr><td>26</td><td>27</td><td>28</td><td>29</td><td>30</td><td>1</td><td>2</td></tr> </table>	SUN	MON	TUE	WED	THU	FRI	±	29	30	31	1	2	3	4	5	6	7	8	9	10	11	12	13	14	15	16	17	18	19	20	21	22	23	24	25	26	27	28	29	30	1	2	<p>7 July</p> <table border="1"> <tr><td>SUN</td><td>MON</td><td>TUE</td><td>WED</td><td>THU</td><td>FRI</td><td>±</td></tr> <tr><td>26</td><td>27</td><td>28</td><td>29</td><td>30</td><td>1</td><td>2</td></tr> <tr><td>3</td><td>4</td><td>5</td><td>6</td><td>7</td><td>8</td><td>9</td></tr> <tr><td>10</td><td>11</td><td>12</td><td>13</td><td>14</td><td>15</td><td>16</td></tr> <tr><td>17</td><td>18</td><td>19</td><td>20</td><td>21</td><td>22</td><td>23</td></tr> <tr><td>24</td><td>25</td><td>26</td><td>27</td><td>28</td><td>29</td><td>30</td></tr> <tr><td>31</td><td>1</td><td>2</td><td>3</td><td>4</td><td>5</td><td>6</td></tr> </table>	SUN	MON	TUE	WED	THU	FRI	±	26	27	28	29	30	1	2	3	4	5	6	7	8	9	10	11	12	13	14	15	16	17	18	19	20	21	22	23	24	25	26	27	28	29	30	31	1	2	3	4	5	6	<p>8 August</p> <table border="1"> <tr><td>SUN</td><td>MON</td><td>TUE</td><td>WED</td><td>THU</td><td>FRI</td><td>±</td></tr> <tr><td>31</td><td>1</td><td>2</td><td>3</td><td>4</td><td>5</td><td>6</td></tr> <tr><td>7</td><td>8</td><td>9</td><td>10</td><td>11</td><td>12</td><td>13</td></tr> <tr><td>14</td><td>15</td><td>16</td><td>17</td><td>18</td><td>19</td><td>20</td></tr> <tr><td>21</td><td>22</td><td>23</td><td>24</td><td>25</td><td>26</td><td>27</td></tr> <tr><td>28</td><td>29</td><td>30</td><td>31</td><td>1</td><td>2</td><td>3</td></tr> </table>	SUN	MON	TUE	WED	THU	FRI	±	31	1	2	3	4	5	6	7	8	9	10	11	12	13	14	15	16	17	18	19	20	21	22	23	24	25	26	27	28	29	30	31	1	2	3
SUN	MON	TUE	WED	THU	FRI	±																																																																																																																																																																												
1	2	3	4	5	6	7																																																																																																																																																																												
8	9	10	11	12	13	14																																																																																																																																																																												
15	16	17	18	19	20	21																																																																																																																																																																												
22	23	24	25	26	27	28																																																																																																																																																																												
29	30	31	1	2	3	4																																																																																																																																																																												
SUN	MON	TUE	WED	THU	FRI	±																																																																																																																																																																												
29	30	31	1	2	3	4																																																																																																																																																																												
5	6	7	8	9	10	11																																																																																																																																																																												
12	13	14	15	16	17	18																																																																																																																																																																												
19	20	21	22	23	24	25																																																																																																																																																																												
26	27	28	29	30	1	2																																																																																																																																																																												
SUN	MON	TUE	WED	THU	FRI	±																																																																																																																																																																												
26	27	28	29	30	1	2																																																																																																																																																																												
3	4	5	6	7	8	9																																																																																																																																																																												
10	11	12	13	14	15	16																																																																																																																																																																												
17	18	19	20	21	22	23																																																																																																																																																																												
24	25	26	27	28	29	30																																																																																																																																																																												
31	1	2	3	4	5	6																																																																																																																																																																												
SUN	MON	TUE	WED	THU	FRI	±																																																																																																																																																																												
31	1	2	3	4	5	6																																																																																																																																																																												
7	8	9	10	11	12	13																																																																																																																																																																												
14	15	16	17	18	19	20																																																																																																																																																																												
21	22	23	24	25	26	27																																																																																																																																																																												
28	29	30	31	1	2	3																																																																																																																																																																												
<p>9 September</p> <table border="1"> <tr><td>SUN</td><td>MON</td><td>TUE</td><td>WED</td><td>THU</td><td>FRI</td><td>±</td></tr> <tr><td>28</td><td>29</td><td>30</td><td>31</td><td>1</td><td>2</td><td>3</td></tr> <tr><td>4</td><td>5</td><td>6</td><td>7</td><td>8</td><td>9</td><td>10</td></tr> <tr><td>11</td><td>12</td><td>13</td><td>14</td><td>15</td><td>16</td><td>17</td></tr> <tr><td>18</td><td>19</td><td>20</td><td>21</td><td>22</td><td>23</td><td>24</td></tr> <tr><td>25</td><td>26</td><td>27</td><td>28</td><td>29</td><td>30</td><td>1</td></tr> </table>	SUN	MON	TUE	WED	THU	FRI	±	28	29	30	31	1	2	3	4	5	6	7	8	9	10	11	12	13	14	15	16	17	18	19	20	21	22	23	24	25	26	27	28	29	30	1	<p>10 October</p> <table border="1"> <tr><td>SUN</td><td>MON</td><td>TUE</td><td>WED</td><td>THU</td><td>FRI</td><td>±</td></tr> <tr><td>25</td><td>26</td><td>27</td><td>28</td><td>29</td><td>30</td><td>1</td></tr> <tr><td>2</td><td>3</td><td>4</td><td>5</td><td>6</td><td>7</td><td>8</td></tr> <tr><td>9</td><td>10</td><td>11</td><td>12</td><td>13</td><td>14</td><td>15</td></tr> <tr><td>16</td><td>17</td><td>18</td><td>19</td><td>20</td><td>21</td><td>22</td></tr> <tr><td>23</td><td>24</td><td>25</td><td>26</td><td>27</td><td>28</td><td>29</td></tr> <tr><td>30</td><td>31</td><td>1</td><td>2</td><td>3</td><td>4</td><td>5</td></tr> </table>	SUN	MON	TUE	WED	THU	FRI	±	25	26	27	28	29	30	1	2	3	4	5	6	7	8	9	10	11	12	13	14	15	16	17	18	19	20	21	22	23	24	25	26	27	28	29	30	31	1	2	3	4	5	<p>11 November</p> <table border="1"> <tr><td>SUN</td><td>MON</td><td>TUE</td><td>WED</td><td>THU</td><td>FRI</td><td>±</td></tr> <tr><td>30</td><td>31</td><td>1</td><td>2</td><td>3</td><td>4</td><td>5</td></tr> <tr><td>6</td><td>7</td><td>8</td><td>9</td><td>10</td><td>11</td><td>12</td></tr> <tr><td>13</td><td>14</td><td>15</td><td>16</td><td>17</td><td>18</td><td>19</td></tr> <tr><td>20</td><td>21</td><td>22</td><td>23</td><td>24</td><td>25</td><td>26</td></tr> <tr><td>27</td><td>28</td><td>29</td><td>30</td><td>1</td><td>2</td><td>3</td></tr> </table>	SUN	MON	TUE	WED	THU	FRI	±	30	31	1	2	3	4	5	6	7	8	9	10	11	12	13	14	15	16	17	18	19	20	21	22	23	24	25	26	27	28	29	30	1	2	3	<p>12 December</p> <table border="1"> <tr><td>SUN</td><td>MON</td><td>TUE</td><td>WED</td><td>THU</td><td>FRI</td><td>±</td></tr> <tr><td>27</td><td>28</td><td>29</td><td>30</td><td>1</td><td>2</td><td>3</td></tr> <tr><td>4</td><td>5</td><td>6</td><td>7</td><td>8</td><td>9</td><td>10</td></tr> <tr><td>11</td><td>12</td><td>13</td><td>14</td><td>15</td><td>16</td><td>17</td></tr> <tr><td>18</td><td>19</td><td>20</td><td>21</td><td>22</td><td>23</td><td>24</td></tr> <tr><td>25</td><td>26</td><td>27</td><td>28</td><td>29</td><td>30</td><td>31</td></tr> </table>	SUN	MON	TUE	WED	THU	FRI	±	27	28	29	30	1	2	3	4	5	6	7	8	9	10	11	12	13	14	15	16	17	18	19	20	21	22	23	24	25	26	27	28	29	30	31
SUN	MON	TUE	WED	THU	FRI	±																																																																																																																																																																												
28	29	30	31	1	2	3																																																																																																																																																																												
4	5	6	7	8	9	10																																																																																																																																																																												
11	12	13	14	15	16	17																																																																																																																																																																												
18	19	20	21	22	23	24																																																																																																																																																																												
25	26	27	28	29	30	1																																																																																																																																																																												
SUN	MON	TUE	WED	THU	FRI	±																																																																																																																																																																												
25	26	27	28	29	30	1																																																																																																																																																																												
2	3	4	5	6	7	8																																																																																																																																																																												
9	10	11	12	13	14	15																																																																																																																																																																												
16	17	18	19	20	21	22																																																																																																																																																																												
23	24	25	26	27	28	29																																																																																																																																																																												
30	31	1	2	3	4	5																																																																																																																																																																												
SUN	MON	TUE	WED	THU	FRI	±																																																																																																																																																																												
30	31	1	2	3	4	5																																																																																																																																																																												
6	7	8	9	10	11	12																																																																																																																																																																												
13	14	15	16	17	18	19																																																																																																																																																																												
20	21	22	23	24	25	26																																																																																																																																																																												
27	28	29	30	1	2	3																																																																																																																																																																												
SUN	MON	TUE	WED	THU	FRI	±																																																																																																																																																																												
27	28	29	30	1	2	3																																																																																																																																																																												
4	5	6	7	8	9	10																																																																																																																																																																												
11	12	13	14	15	16	17																																																																																																																																																																												
18	19	20	21	22	23	24																																																																																																																																																																												
25	26	27	28	29	30	31																																																																																																																																																																												



2段4分の1の広告サイズは  
タテ**61mm**×ヨコ**59mm**となります

制作する際のサイズは、上記サイズから  
枠の太さ**0.5mm**を引くため、  
タテ**60.5mm**×ヨコ**58.5mm**となります

その他サイズ例

	外枠サイズ (タテmm×ヨコmm)	制作サイズ
半2段	(61×120)	60.5×119.5
半4段	(124×120)	123.5×119.5
全3段	(92×244)	91.5×243.5

(例)  
2段4分の1枠(タテ61mm×ヨコ59mm)

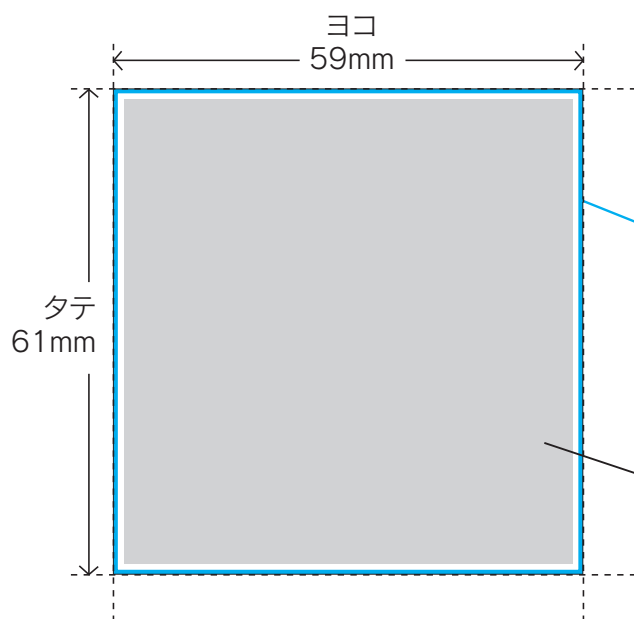

- ・枠の太さ…0.5mm
- ・スミ100%
- ・枠のみのレイヤーを最前
- ・枠に塗りはつけない

- ・文字は枠から内側に1mm縮小した範囲内に収めてください(地色、画像は外枠までOK)
- ・枠内全面の地色がスミ100%は不可
- ・画像はpsd形式 CMYK  
※CMYKに変更されていないRAWデータまたは、撮影されたままのRGB画像がございましたらご添付ください
- ・色のかけあわせは4版合計で260%以下

#### 文字について

- ・文字は最小3ptまで
- ・最小文字の場合スミ100%で、なるべく背景は白(ゴシック書体の使用を推奨します)
- ・細すぎる書体はなるべく避けてください

#### ◆ Illustrator

CMYKでai保存  
文字(フォント)は**全てアウトライン化**

#### ◆ Photoshop

CMYKでpsd保存 UCR値(インキ総量)260%以下  
解像度300dpi  
※配置写真データは必ず添付してください。  
※CMYKに変更されていないRAWデータまたは、  
撮影されたままのRGB画像がございましたらご添付ください

**出力見本と一緒に入稿してください。**

エリート情報社ホームページ



「エリート情報」のバックナンバーが閲覧可能(1年前までの発行分のみ)

各ジャンル店舗情報が閲覧可能

スタッフがSNS等で多彩な情報を発信



You Tube  
オンラインコミックetc…

エリート情報社 <http://www.elite-joho.com>

その他、シネアド(映画CM)や駅デジタルサイネージ、スマホオリコミなどの各種販促物もご要望に応じて承ります。お気軽にご相談ください。

株式会社 エリート情報社

〒286-0134 千葉県成田市東和田415-10

☎0476-22-4401 / FAX 0476-24-0704

担当: